

(PL) Instrukcja montażu

(CZ) Návod k montáži

(D) Montageanleitung

(GB) Assembly instruction

(F) Model d'emploi

(HU) Szerelési útmutató

(I) Istruzione di montaggio

(NL) Handleiding voor de montage

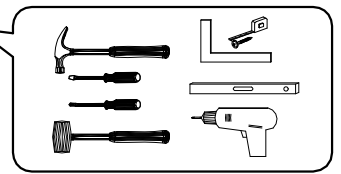
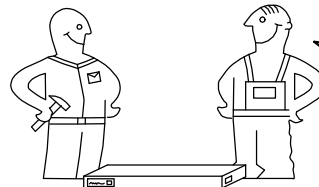

(RU) Инструкция по монтажу

(RO) Instrucțiuni de montare

(SK) Návod k montáži

(TR) Montaj talimatı

⚠ <b>Uwaga • Upozornění • Achtung • Attention • Caution • Figyelem</b> <b>Attenzione • Opgelet • Внимание • Atenție • Upozornenie • Dikkat</b> ⚠	
PL	Czyszczenie należy wykonać wyłącznie za pomocą ściereczki lub lekko nawilżonego ręcznika. Nie stosować środków czyszczących do szorowania.
CZ	Čistění je nutné vykonávat výhradně pomocí utěrky nebo lehce navlhčeného ručníku. Nepoužívejte čisticí prostředky obsahující abrazivní částice.
D	Bitte nur mit einem Staubtuch oder leicht feuchtem Lappen reinigen. Keine scheuernden Putzmittel verwenden.
GB	Please only clean with a duster or a damp cloth. Do not use any abrasive cleaners.
F	Le nettoyage se fait uniquement à l'aide d'un torchon ou d'une serviette légèrement mouillée.
HU	A tisztítás kizárólag törülköruha vagy enyhén nedvestett törölköző segítségével végezhető. Súroló hatású tisztítószereket nem szabad használni.
I	Pulire esclusivamente con un panno o un asciugamano umido.
NL	Reinig alleen met een stofdoek of een lichtjes vochtige doek. Gebruik geen schurende poetsmiddelen.
RU	Очищайте от пыли тряпкой или слегка влажной ветошью. Не допускается применение чистящих средств, не предназначенных для ухода за мебелью.
RO	Curățarea trebuie efectuată numai cu o cârpă sau cu un prosop ușor umezit. Nu utilizați agenți de curățare abrazivi.
SK	Čistení je nutné vykonávať výhradne pomocou utierky alebo ľahko zvlhnutým ručníkom. Nepoužívajte čistiace prostriedky obsahujúci abrazívne častice.
TR	Lütfen sadece bir toz bezilye veya hafif nemli yumuşak bir bezle siliniz. Aşındırıcı temizlik malzemeleri kullanmayınız.

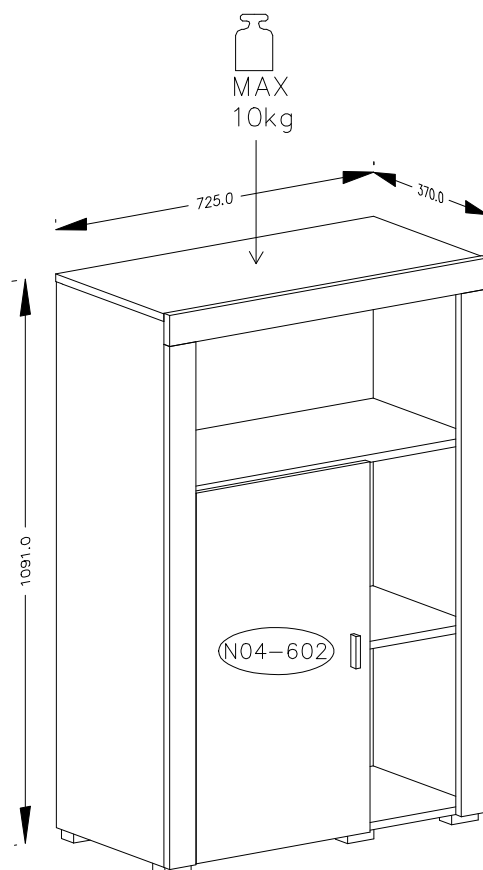
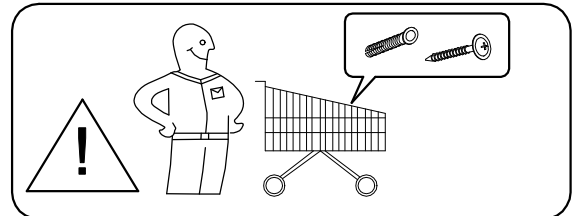
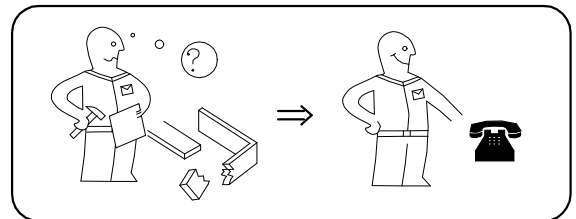
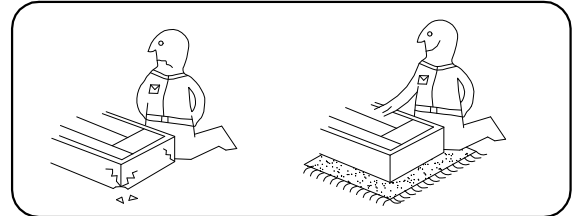





# NELA 44



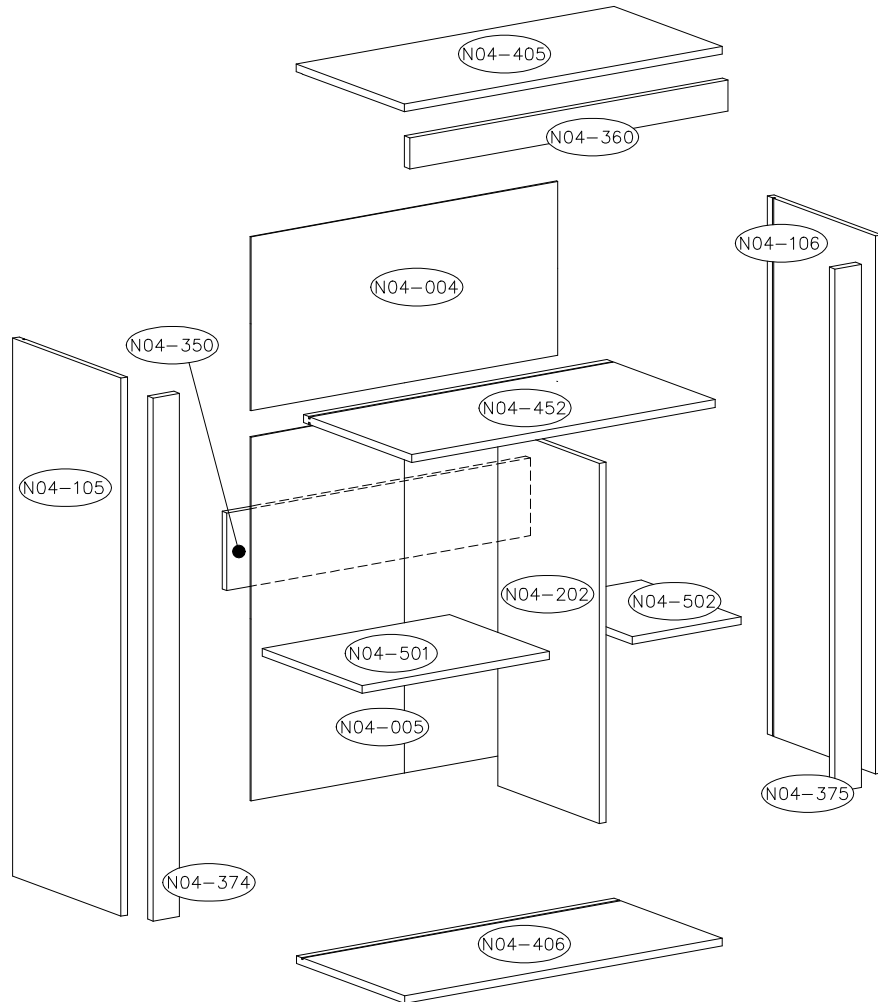

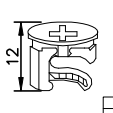
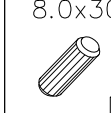
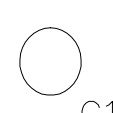

MAX  
5kg

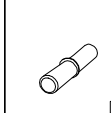
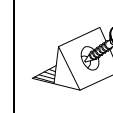
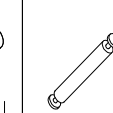
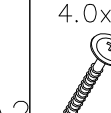
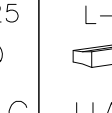
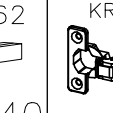
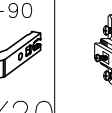
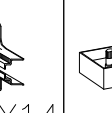
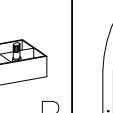
N04-452 N04-501 N04-502

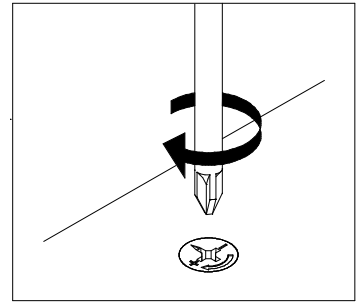
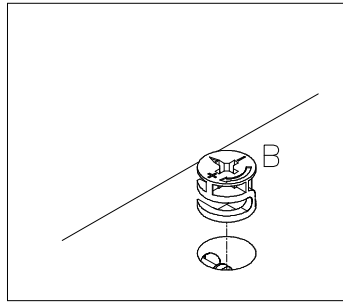
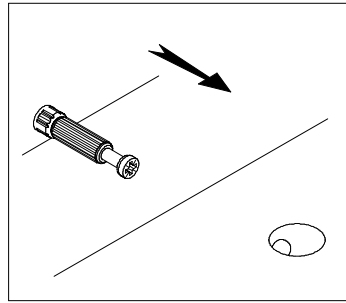
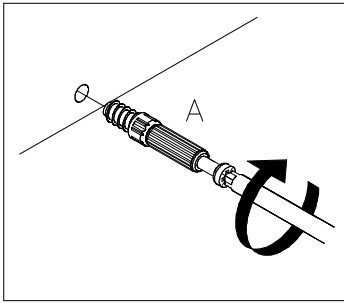

 A	 B	 D									
27	31	26									
 C1	 F	 E	 J	 A2	 G	 UA40	 Y20	 X14	 P	 J2	
22	4	8	14	2	2	1	2	2	6	1	

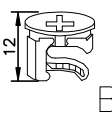

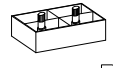

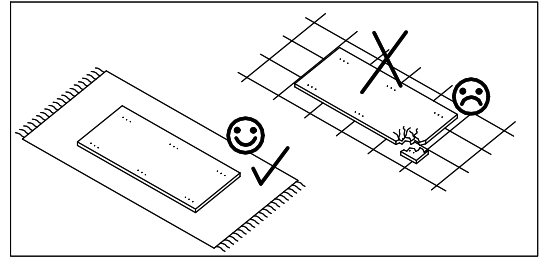
			
A	B	D	P
8	13	14	6



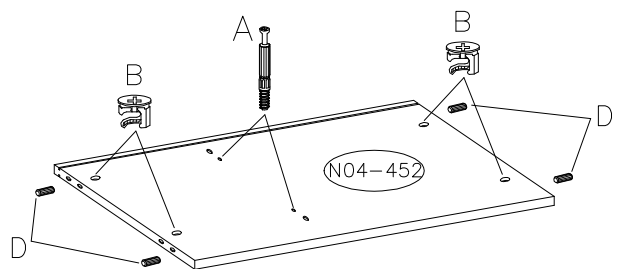
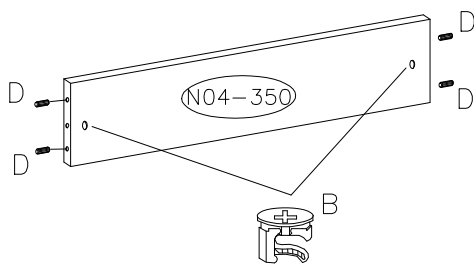
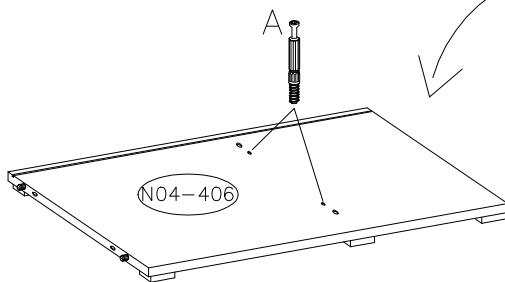
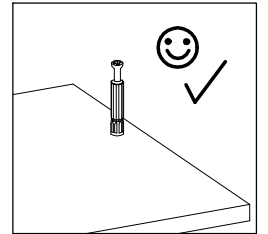
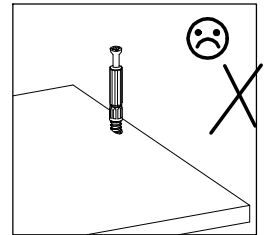
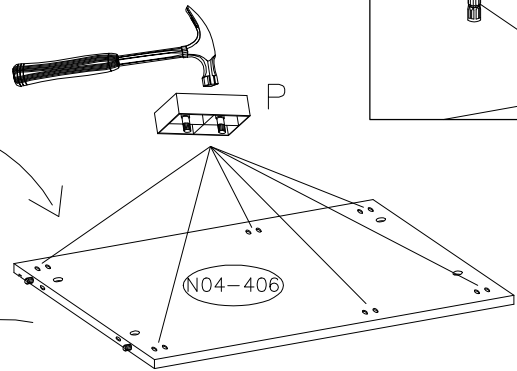
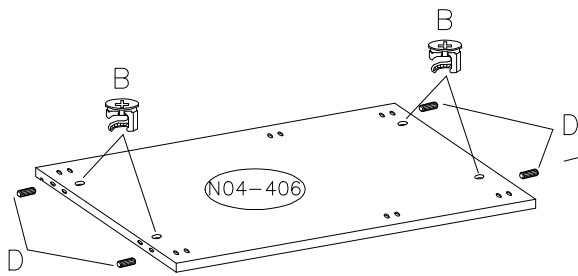
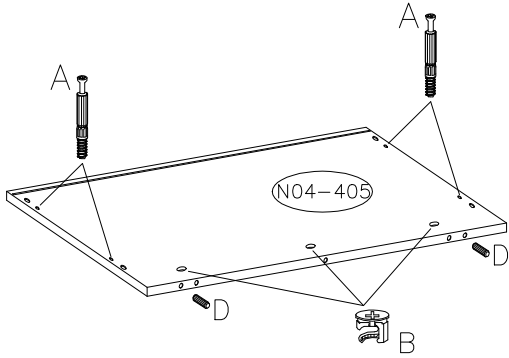

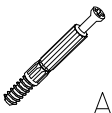
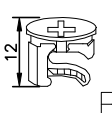
1



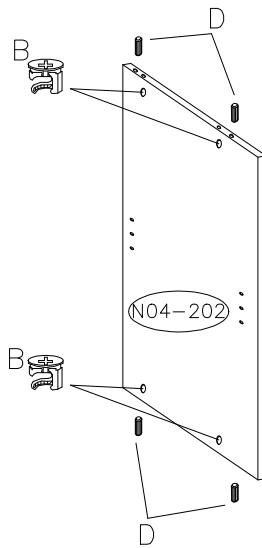
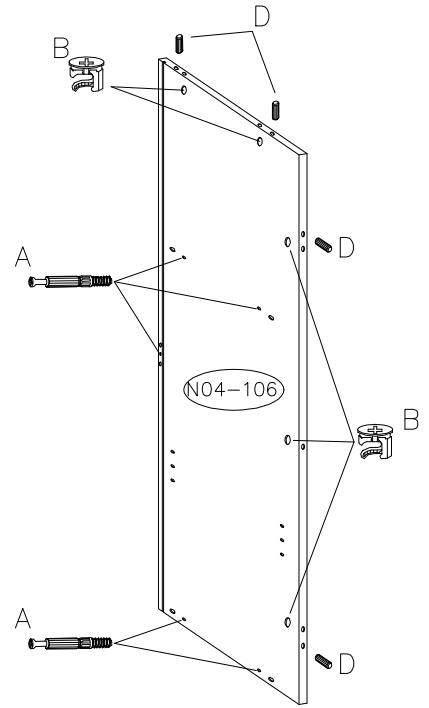
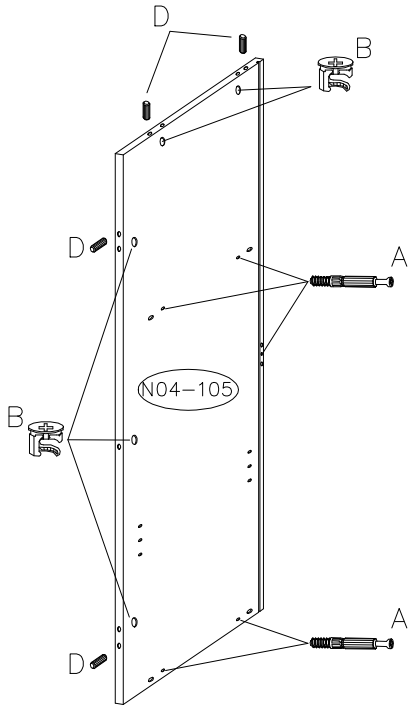

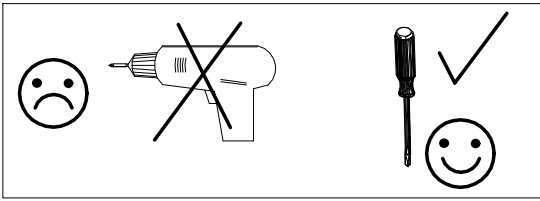
 A	 B	 8.0x30 D
10	14	12

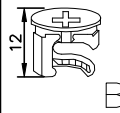

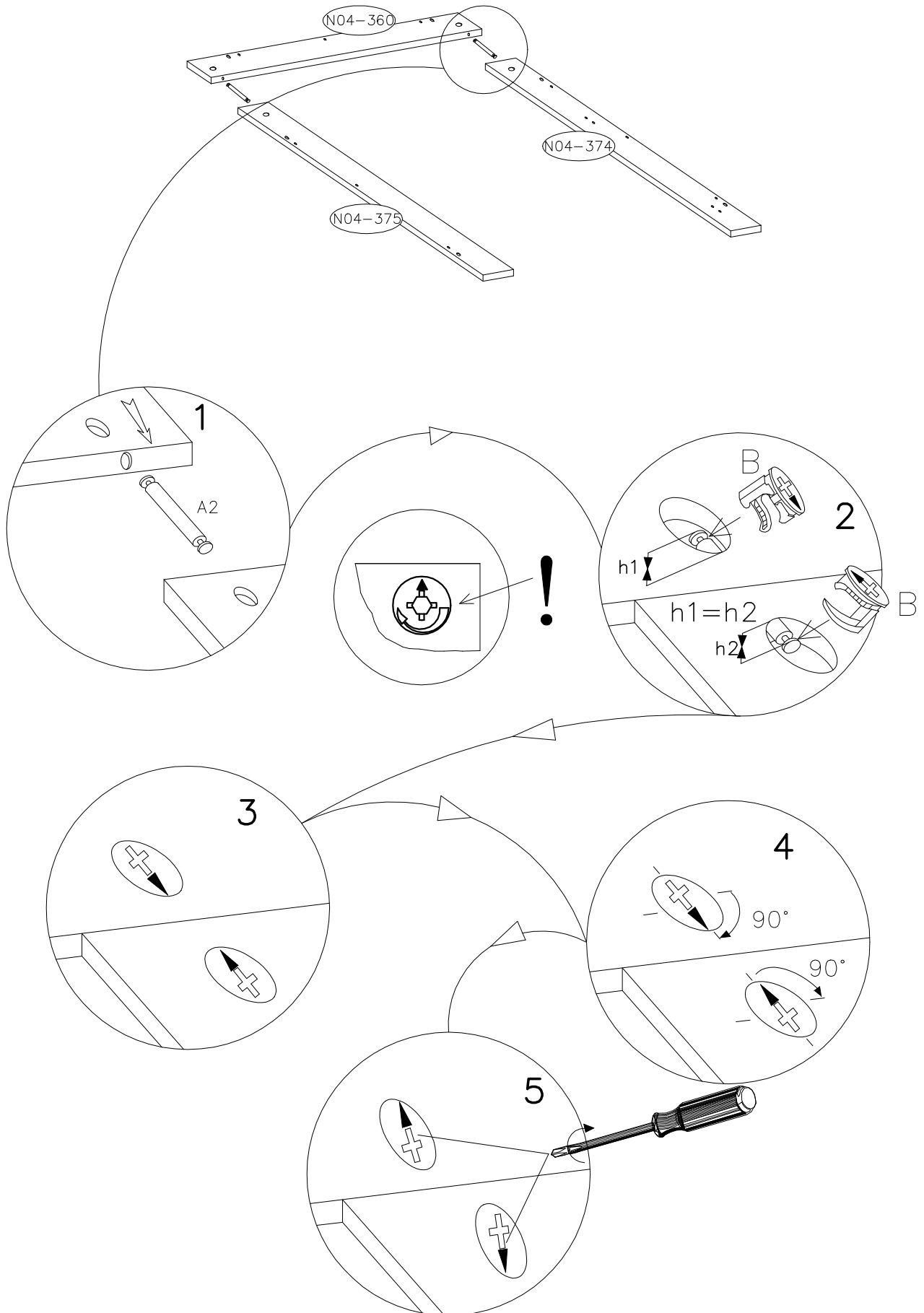

 12 B	 A2
4	2



 X14	 A
2	9

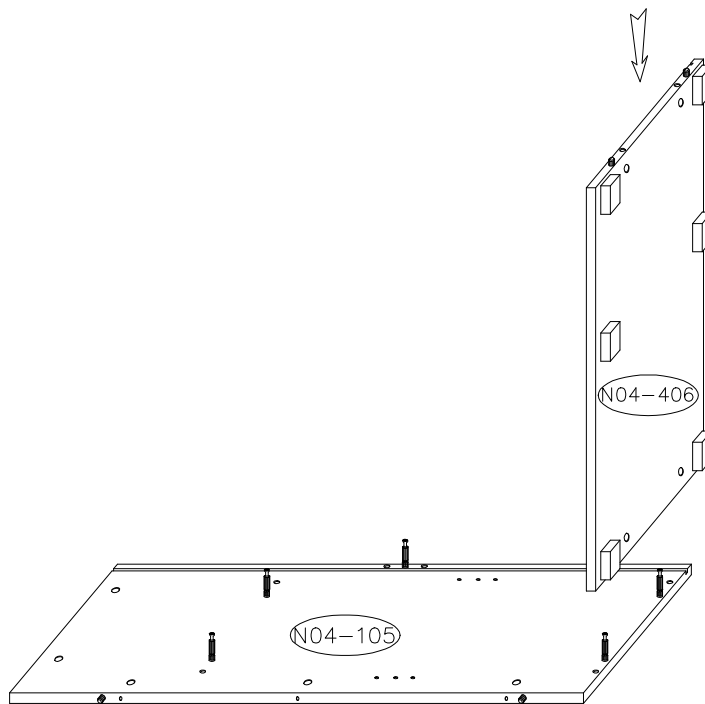
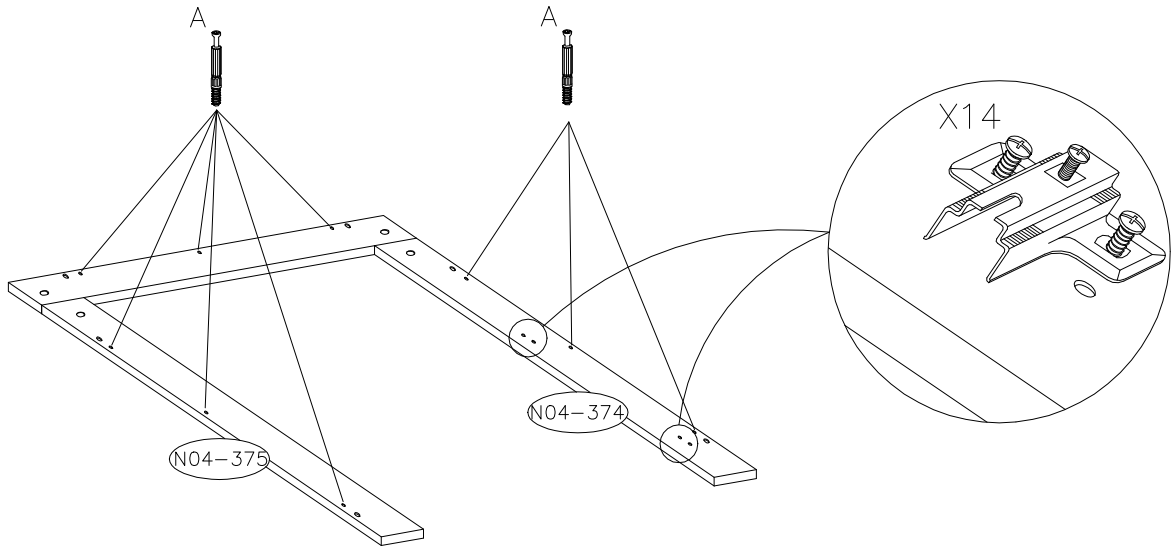

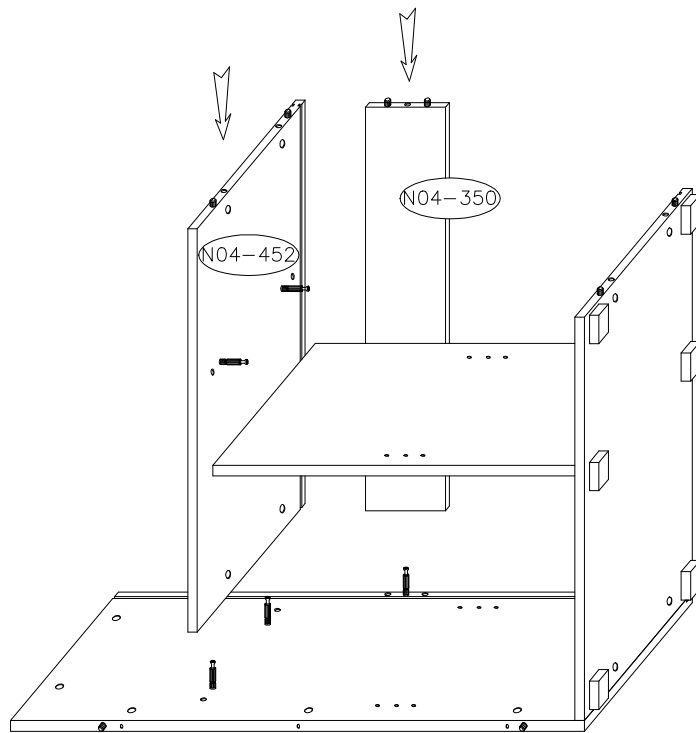
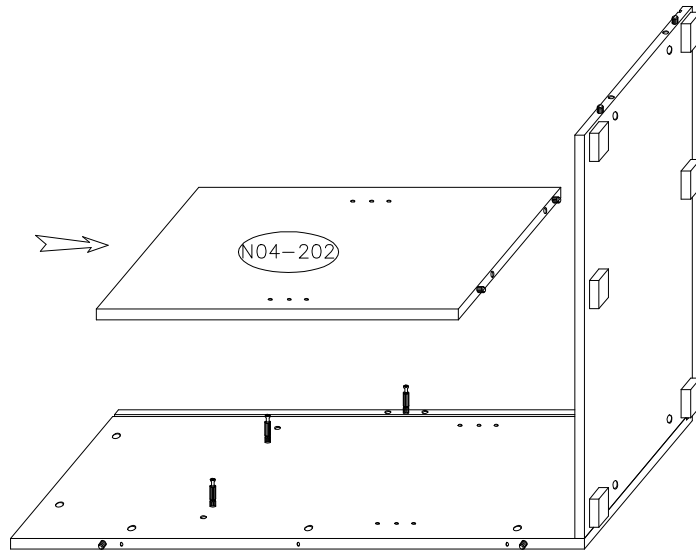

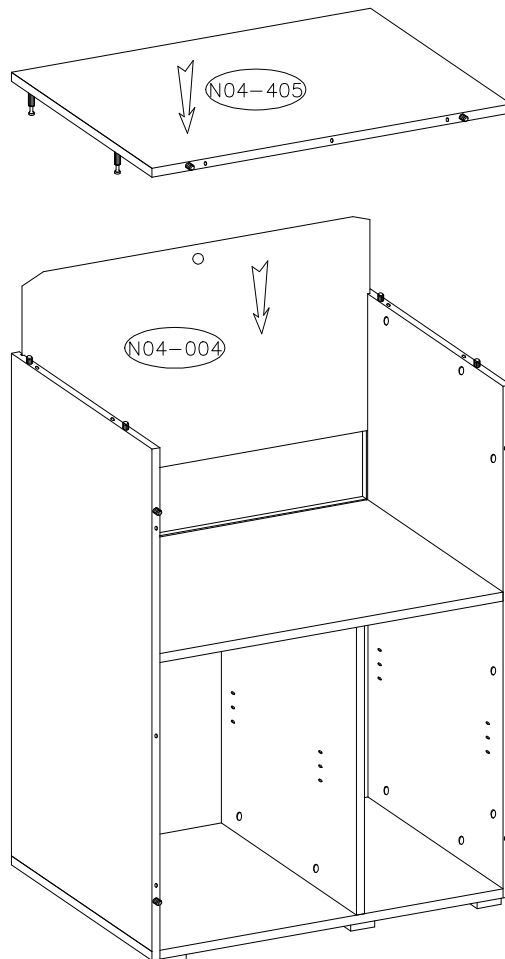
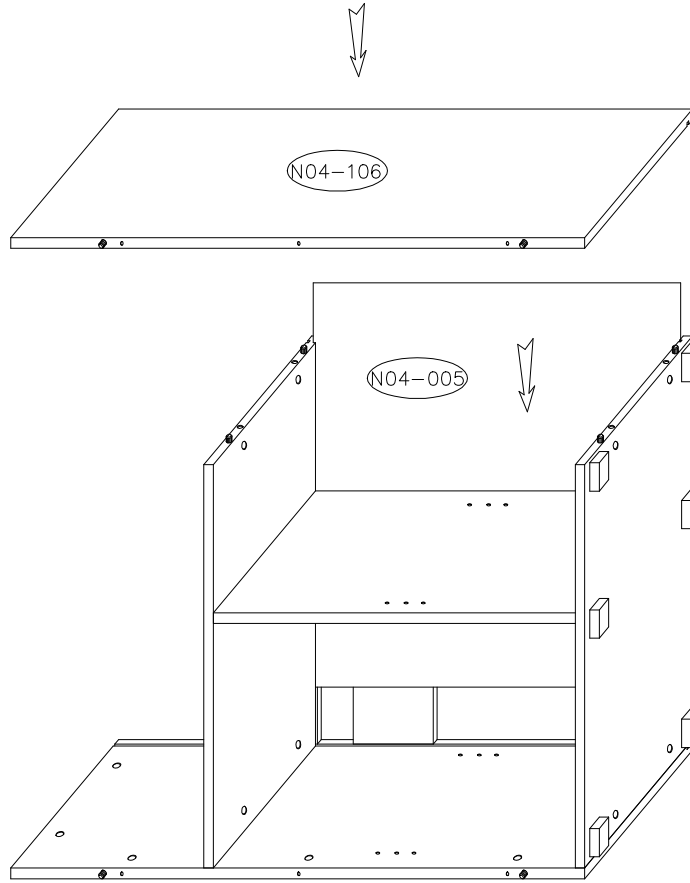



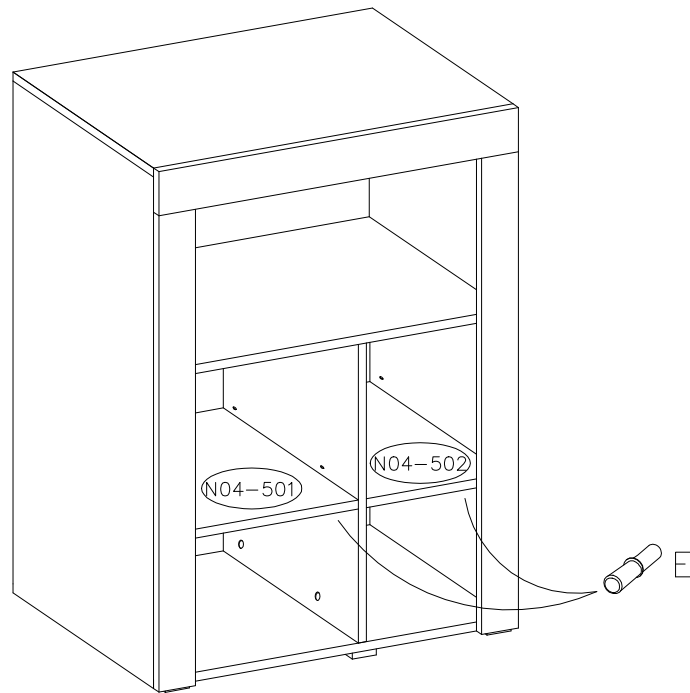
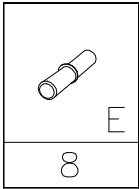
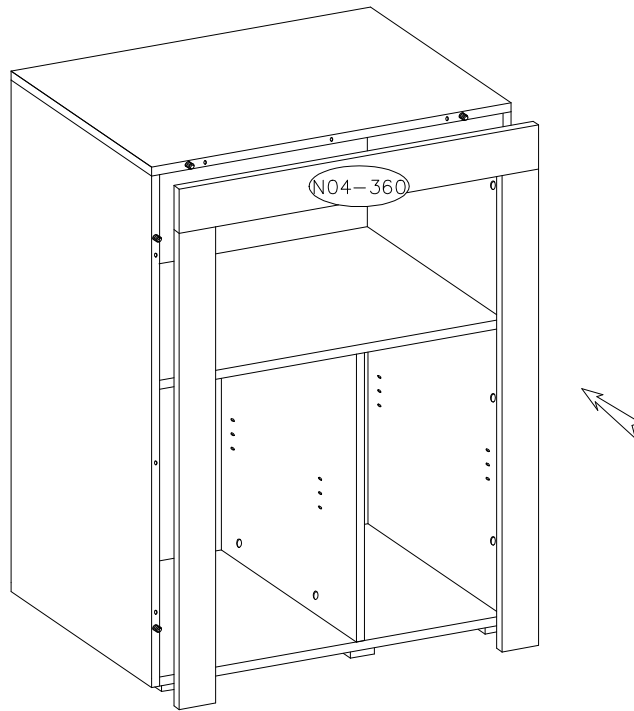

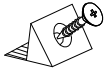

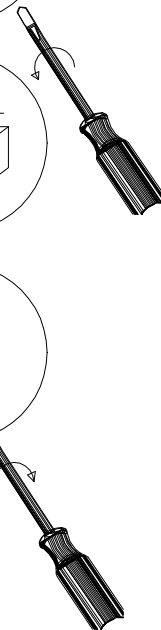
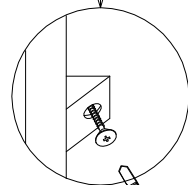
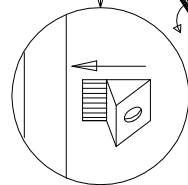
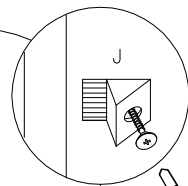
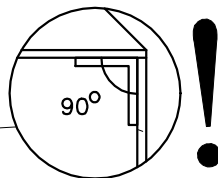
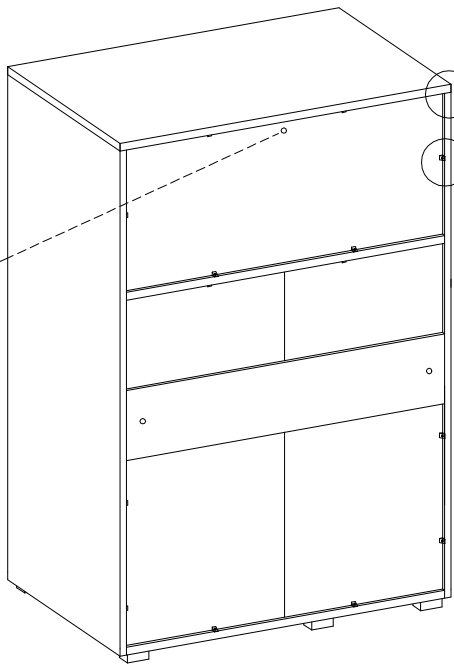

 C1	 J
1	14

C1 

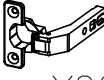

6.3x13  F	4.0x25  G	L-62  UA40	KR-90  Y20
4	2	1	2

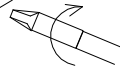
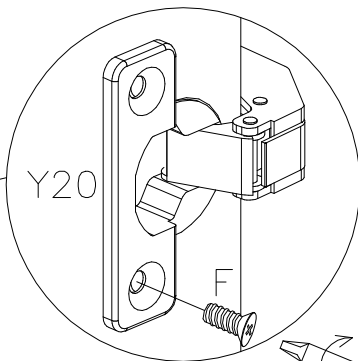
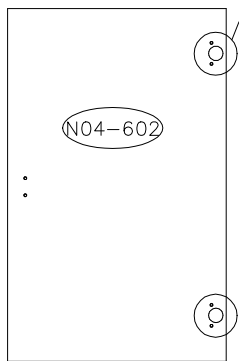

UA40

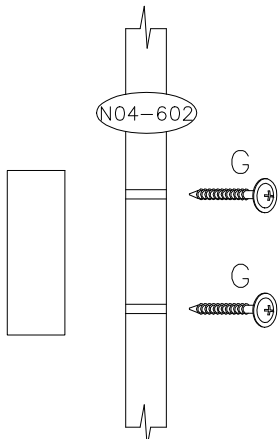

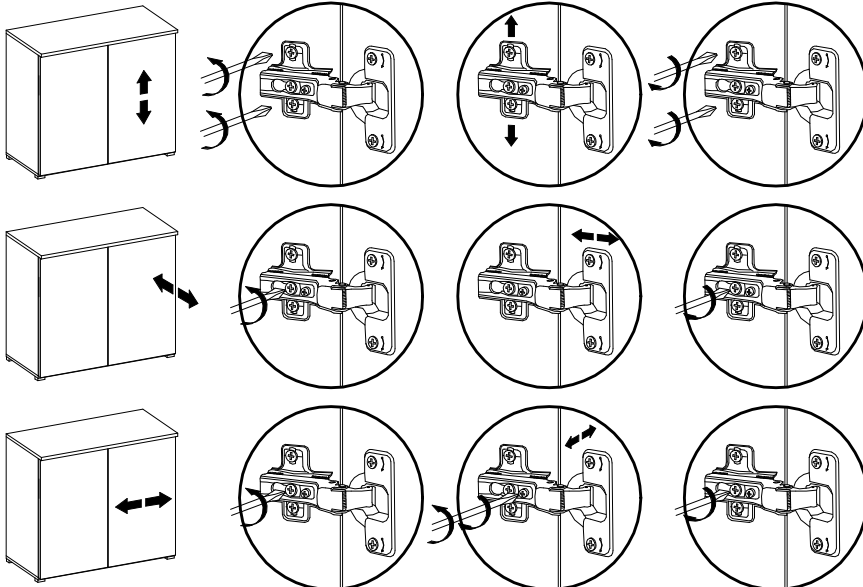
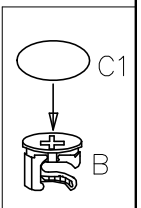
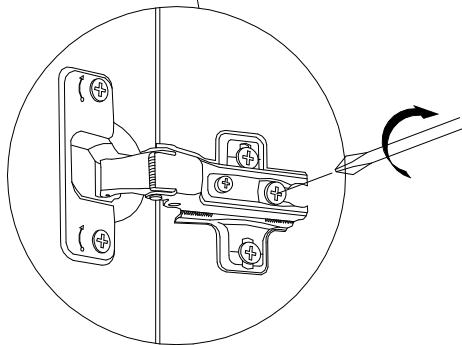
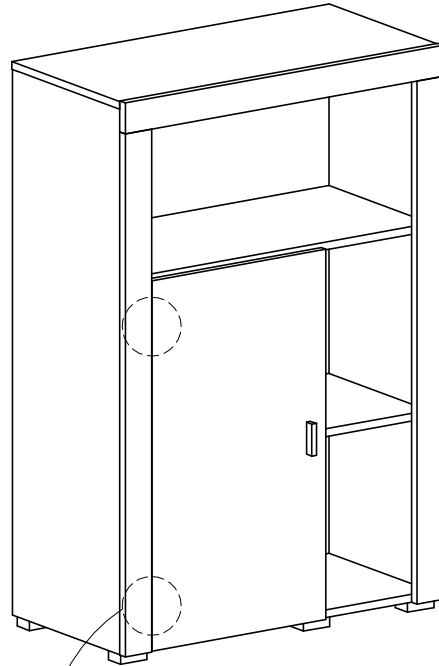
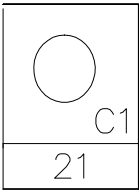

- F** Mettre la porte (égaler les gonds)
- I** Regolare la porta (livellare le parentesi)
- D** Turen einstellen (Scharniere justieren)
- GB** Adjusting the doors (adjusting the hinges)
- NL** Deuren instellen (scharnieren afstellen)
- PL** Nastawic drzwi (wyrównac zawiasy)
- TR** Kapıların ayarlanması (menteşelerin seviye ayarı)
- RU** Регулировка дверей (регулировка шарнира)
- RO** Ajustați ușa (aliniati balamalele)
- CZ** Seřid'te dveře (vyrównajte závěsy)
- SK** Zrad'te dvere (vyrównajte závesy)
- HU** Állítsa be az ajtót (igazítsa be a zsanérokot)

1

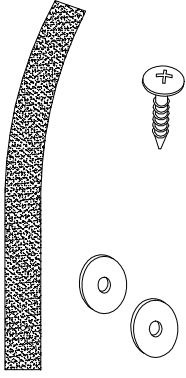

<b>Uwaga • Upozornini • Achtung • Attention • Caution • Figyelem</b> <b>Attenzione • Opgelet • Внимание • Atentie • Upozornenie • Dikkat</b>	
PL	Mocowanie do ściany jest jednocześnie zabezpieczeniem przed przewróceniem – konieczne zamontować! Do niektórych rodzajów ścian konieczne zastosować specjalne kołki mocujące. Montaż na ścianie służy jako ochrona przed przewróceniem – bezpodmiennie umieścić! U niektórych typów ścian może być potrzebny specjalny hmoždinka!
CZ	U některých typů stěn může být zapotřebí speciální hmoždinka!
D	Wandbefestigung dient als Kippschutz – unbedingt anbringen! Bei einigen Wandtypen kann ein Spezialdübel erforderlich sein!
GB	The wall fastening serves to prevent tipping – be absolutely sure to mount it! For certain wall types, a special wall plug may be necessary!
FR	La fixation murale sert de protection contre le basculement – à installer impérativement ! Pour certains types de murs il faut des chevilles spéciales !
NL	Bevestiging aan de muur dient als kantelbescherming – zeker en vast bevestigen! Bij enkele muurtypes is een speciale plug misschien vereist!
IT	Il fissaggio alla parete serve da protezione anti-ribaltamento – attaccarlo assolutamente! Per alcune strutture di parete può essere necessario un tassello speciale!
HU	A termékét a falhoz kel rögzíténi, különben az felborulhat! Egyes faltípusoknál speciális tiplit kell használni!
RU	Обязательно установите крепление на стене во избежание опрокидывания! Для некоторых типов стен может потребоваться специальная дюбель!
RO	Sistemul de fixare la perete serve ca protecție la răsturnare – de montat obligatoriu! Pentru unele tipuri de pereți este posibil să fie necesar un diblu special!
SK	Upevnenie na stenu slúži ako ochrana proti prevráteniu – bezpodmienečne použiť! Pre niektoré druhy stien môže byť potrebná špeciálna hmoždinka!
TR	Duvardaki sabitleme, devrilmeye karşı bir emniyet tedbiridir ve mutlaka monte edilmelidir! Bazı duvar tiplerinde bunun için özel bir dübel gerekli olabilir!

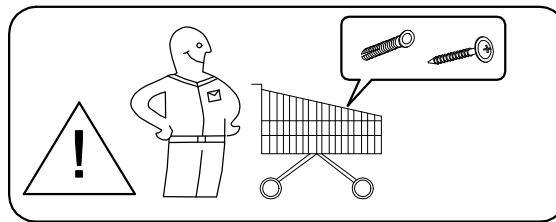
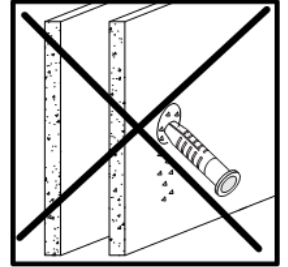
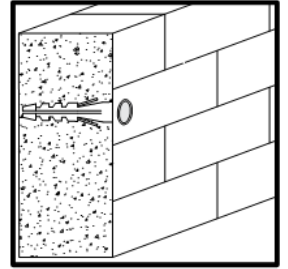

2a

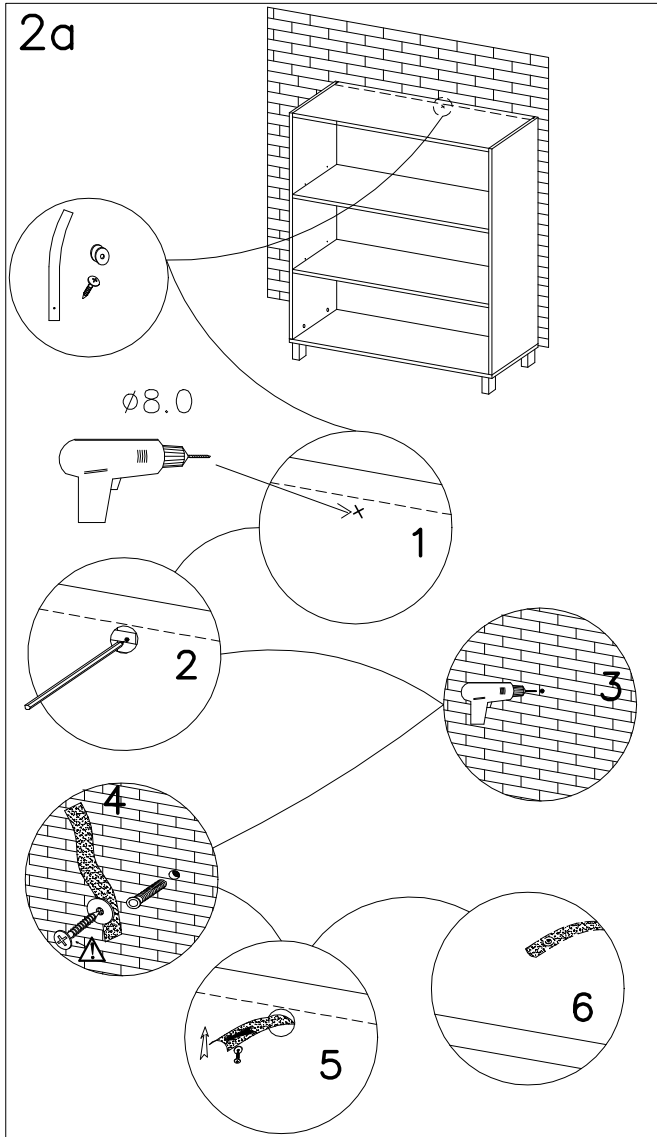

2b

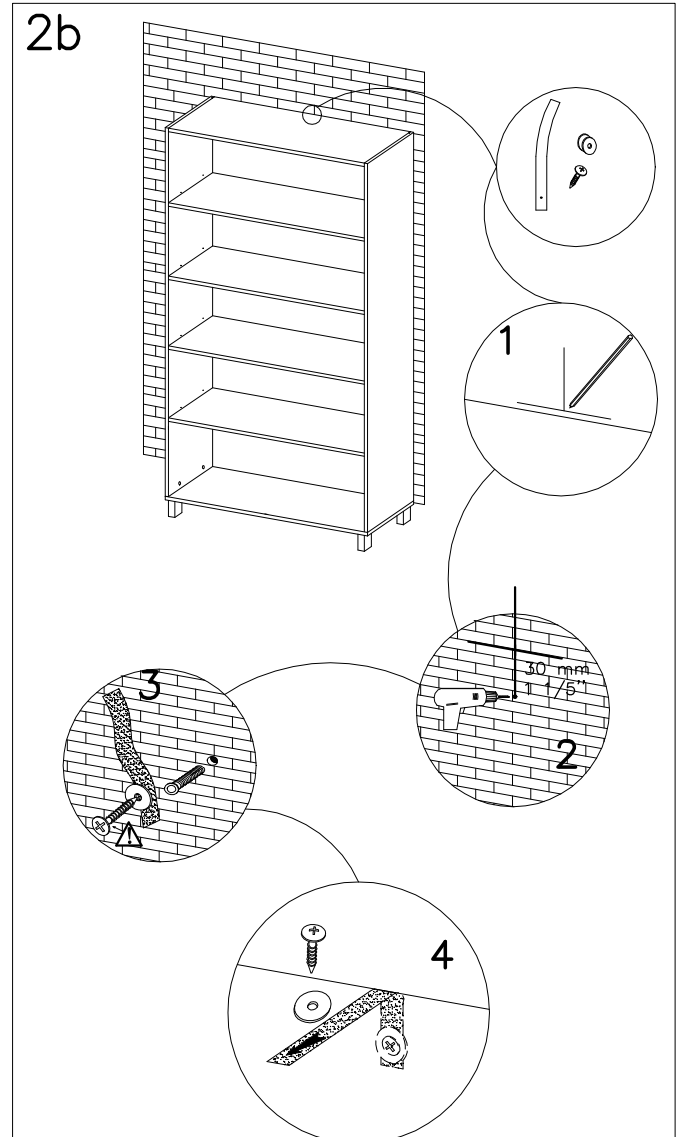

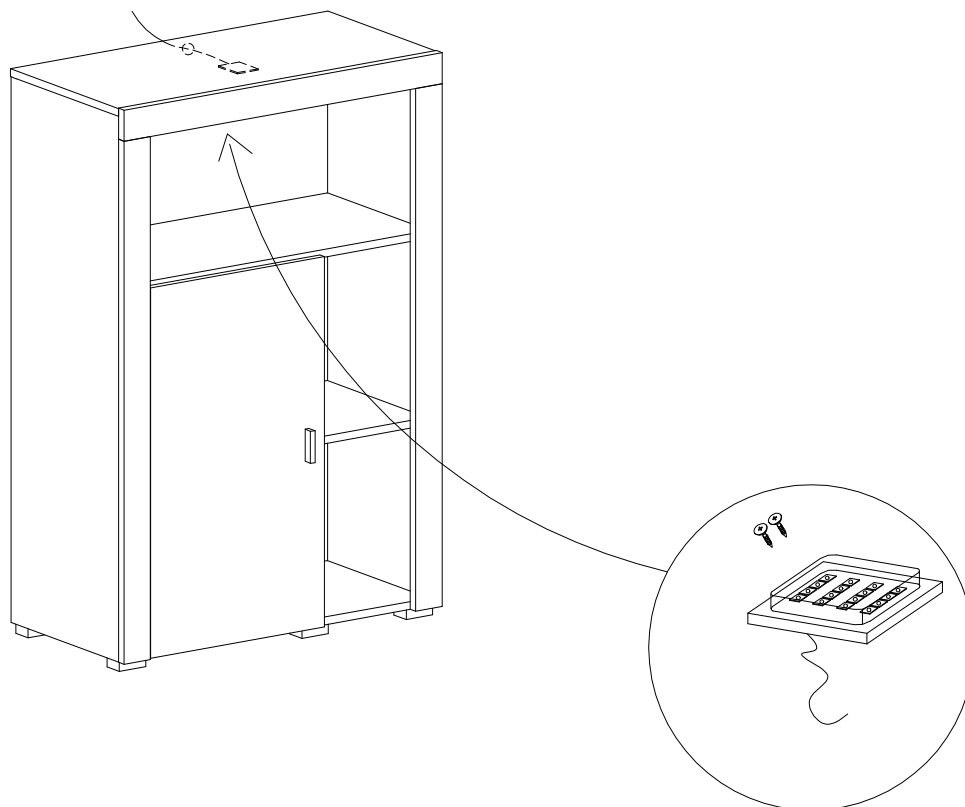
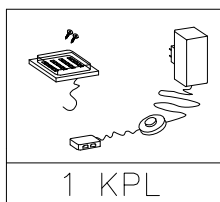

- (PL) **Uwaga: Punkty mocowania opcjonalnego oświetlenia**
- (CZ) **Upozornění: body k připevnění doplňkového osvětlení**
- (D) **Hinweis: Befestigungspunkte für optionale Beleuchtung**
- (GB) **N.B.: Fixing points for optional lighting**
- (F) **Remarque: Points de fixation de l'éclairage optionnel**
- (HU) **Figyelem: Opcionális világítás rögzítési pontjai**
- (I) **NOTA: punti di fissaggio opzionale dell'illuminazione**
- (NL) **OPGELET: Optionele bevestigingspunten van de verlichting.**
- (RU) **ВНИМАНИЕ: Точки крепления дополнительного освещения**
- (RO) **Atenție: Punctele opționale de fixare a iluminatului**
- (SK) **Upozornenie: body k pripevnení dodatočného osvetlení**
- (TR) **Dikkat: Seçenekli aydınlatmanın yerleştirilmesinin noktaları**